

# DOOSAN

Wheel Loaders |  
DL300-5 / DL350-5



Maximum power: 271 HP / 271 HP  
Operating weight: 18,865 kg / 19,625 kg  
Bucket capacity: 3.0 m<sup>3</sup> / 3.5 m<sup>3</sup>



# Doosan Group – Building your tomorrow today

## Be part of the great Doosan family

The Doosan Group – founded in 1896 and headquartered in Seoul, South Korea – is one of the fastest-growing companies in the world:

- With more than 43,100 employees in 34 countries, we are a major player in a variety of industries worldwide
- We are a global leader in the Infrastructure Support Business (ISB), with 56 subsidiaries and 3,700 distributors worldwide
- Dramatic growth over the past decade, with 23% average annual revenue growth since 2000 and rising from €2.4 billion in 1998 to €18.0 billion in 2011

## Doosan Group – a top player worldwide



### Doosan Engines

- World N° 2 in medium-speed marine diesel engines



### Doosan Engineering & Construction

A pioneering leader in construction of residential and public buildings, civil works and industrial facilities.

- World N° 1 chemical process equipment products



### Doosan Heavy Industries & Construction

- World N° 1 in desalination plant construction
- World N° 1 in heat recovery steam generator market
- World N° 1 in mould & tool steel
- World N° 3 in crankshafts



### Doosan Infracore

- Among the world's Top 5 manufacturers of construction equipment
- World N° 1 in compact loaders
- World N° 1 in attachments
- World N° 1 in portable air compressors



## Doosan Infracore Construction Equipment

### Creating construction equipment for over 40 years

For over 40 years, we've been building a global production and business network to become one of the world's foremost construction equipment manufacturers.

### A solid partner, close to you

A truly global player in every respect, we have large-scale factories, sales subsidiaries and dealers all over the world.



Doosan facilities in Europe

▣ **From machine manufacturer... to full solution provider**

To ensure the highest trade-in and residual values, our parts and service support professionals maintain the performance, productivity and reliability that you expect of our products throughout their lifetime.

▣ **Ask your dealer for a full range of services designed especially for you!**

As your local specialist, your dealer ensures that you receive the maximum benefit from our integrated package. Plan ahead to ensure the success of your equipment!



Doosan approved attachments



Genuine parts



Extension of warranty



Financial solutions



Maintenance contract



Telematics



Monitoring systems



▣ **Simplicity works when it comes to Doosan's product range...**



Articulated Dump Trucks



Special Applications



Wheel Loaders



Wheeled Excavators



Compact Excavators



Crawler Excavators

# Raise productivity, fuel-efficiency & profits

## ► Productivity

Thanks to their robust design and the use of high-quality components, the Doosan wheel loaders deliver very high performance – ensuring you the best productivity and reliability.

⊙ **Z-bar:** "Z" kinematic delivers a huge break-out force, especially for heavy materials, and a large dump angle for unloading sticky materials efficiently.

⊙ **Worktools:** Wide range of heavy-duty attachments to answer all of your needs.

⊙ **Linkage:** Direct mount for the best performances or via a hydraulic quick coupler to change & lock work tools quickly and safely from inside the cab.

⊙ **Simplicity of operations:** "Lift arm raise kick-out" and "return to dig" bucket – Automated functions operated electronically from inside the cab.

⊙ **Versatility:** 3rd valve (standard) increases the versatility of your investment.

⊙ **Load Isolation System:** Ride control (standard) reduces pitch effect and vibrations to provide the best comfort.

⊙ **Automatic differential lock:** Limited slip or hydraulic lock – the machine delivers all of its performance, while preserving fuel consumption and reducing wear on the tyres.

⊙ **Hydraulic system:** Load sensing closed centre system provides the operator with precision & smoothness while reducing fuel consumption.

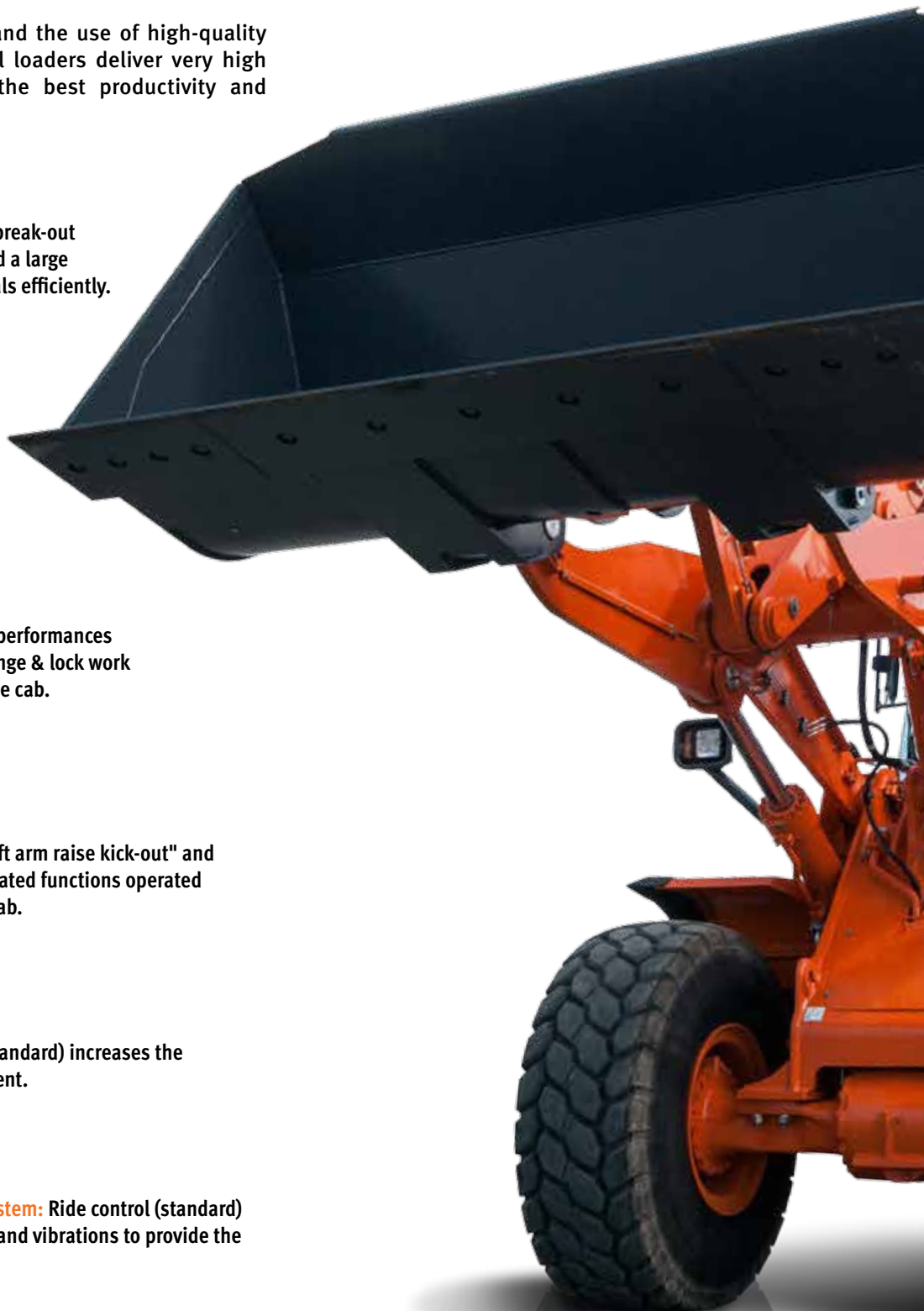

## Total cost of ownership ▲

Minimising your operating costs is at the heart of the Doosan wheel loaders' design, every day.

⊕ **Safety:** Always a critical factor for your company and your employees – so, these machines feature large platforms, hand-rails, and 2 emergency exits, with maintenance performed from the ground.

⊕ **Spacious cab:** Operator enjoys comfortable driving, with many ergonomic features as standard.

⊕ **Power:** Exceptionally powerful, with high torque at low revs, the Stage IV compliant Scania engines do not need a Diesel Particulate Filter (DPF) and associated regeneration system, so they deliver greater fuel efficiency.

⊕ **Efficient fuel management:** This generation of Scania engines enables up to 10% fuel reduction. Engine shut-off provides an additional max. 5% reduction.

⊕ **Cooling performances:** Cooling compartment separated from the engine compartment to prevent warm and dusty air from entering and allow better control of air intake. Automatically reversing fan as standard.

⊕ **Full fenders:** As standard, to keep your machine clean and your operators even safer.

⊕ **Serviceability:** Spacious access to main components allows quick and easy daily maintenance.

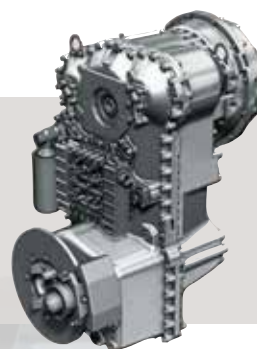

**Powertrain:** 5-gear ZF PowerShift transmission, with automatic and manual shift modes, plus torque converter with “lock-up” function for lower fuel consumption and an impressive speed in climb.

# Top performance and fuel efficiency



## Strength and intelligence – a winning combination!

Exceptional power – combined with the finest workmanship – results in a machine that performs at the highest level. The DL300-5 & DL350-5 enhance your output from every angle:

- Impressive breakout force and high traction make penetration easy and allow you to tackle the hardest materials
- Powerful hydraulic system makes work quick and efficient
- New Scania DC9 engine with SCR technology provides the power you need while meeting Stage IV environmental regulations

The combination of these features gives Doosan wheel loaders excellent penetration power, ensuring optimum bucket load in each cycle.



### New engine – lower emissions / higher torque

The DL300-5 & DL350-5 are equipped with Scania engines. Renowned for excellent fuel efficiency, reliability and long service life, they combine exceptional power output with high torque at low revs. For faster machine response – even at very low speed – XPI (extra-high pressure injection) common-rail fuel injection (2400 bar) is combined with a Variable Geometry turbocharger.

Selective Catalytic Reduction (SCR) technology, combined with a Diesel Oxidation Catalyst (DOC), ensures compliance with Stage IV environmental regulations. As there is no need for a particulate filter, there is no need for regeneration.



### Tailored performance

You can select from 3 different working modes: ECO, Normal and Power, while the Power-up function lets you switch the machine into a higher working mode with lower transmission shift intervals by fully applying the acceleration pedal.

### Save fuel, save money

To improve your fuel efficiency, an auto shut-down reduces the idle time of the engine, to prevent the over-consumption and useless operating hours. You can easily set the auto shut-down (to stop the engine after 3 to 60 minutes) via the LCD display.

### ECO gauge

Shows the average fuel efficiency for 1 minute of operation.

### Transmission

The Doosan ZF transmission has 5 gears (depending on the country) to boost acceleration performance, especially on climbs with the lock-up. The gear ratios are optimised and smooth, and shock-free shifts contribute to the high overall level of operator comfort. Traction force is also maximised.

Together, these qualities enable high working speed in all conditions. The transmission has 3 operating modes:

- Manual
- Automatic (working, 1<sup>st</sup> to 5<sup>th</sup> gear)
- Automatic (travelling, 2<sup>nd</sup> to 5<sup>th</sup> gear)

An automatic kick-down improves the machine's penetration into the pile.

### Load sensing hydraulic closed centre system

This system provides maximum hydraulic performance, without producing excess capacity, thus saving fuel and extending the lifetime and reliability of vital components (such as the pumps and the main control valves).



**Lock-up:** The DL300-5 & DL350-5 also feature torque converter lock-up. When this is activated, the engine automatically connects directly to the transmission (depending on speed and travel resistance), even from 2nd gear. The transmission receives the full engine power without hydraulic slip – thus increasing speed on slope dramatically.

This feature can save you up to 10% in fuel costs.

# Operating in comfort

## Comfort – why do without?

The productivity of your wheel loader is directly linked to the operator's performance. That's why Doosan has placed comfort at the very centre of its design priorities for the DL300-5 & DL350-5.

More space, better visibility, a high comfortable seat, and plenty of storage space make it easy to work for hours without fatigue or discomfort. And there's no need to pay extra for the options you want – most of them are standard features on this loader!

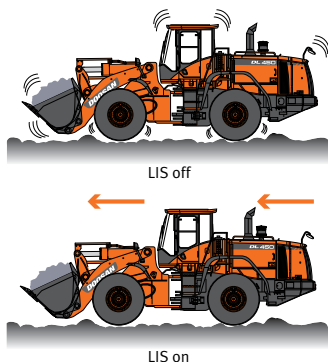

### Operator environment

A modern and attractive work space offers generous headroom, and seat movement provides lots of leg room. Interior materials are selected for their high quality and easy cleaning. In addition, your belongings are right at hand, thanks to several storage boxes throughout the cab.

### Comfortable automatic lift arm

Save time and reduce the number of operations with the "lift arm raise kick-out" and "return to dig" system. These functions are operated electronically from inside the cab.

### High-comfort air suspension seat

With vertical and horizontal suspension, the ultra-comfortable, heated and fully adjustable Grammer seat is featured as standard, giving you the feeling of being comfortably installed in your own sofa.

### Load Isolation System

This standard feature provides a smooth ride over rough ground, operator comfort, and reduced cycle times due to improved vehicle stability in movement. Higher productivity and better fuel efficiency while performing load & carry applications. Speed for automatic activation is adjustable by the operator.

### Accurate & smooth joystick steering

Keep your concentration and reduce strain with the comfortable joystick steering integrated on the armrest. Drive your machine easily, especially in repetitive tasks and tight spaces.

### Automatic air conditioning

Day and night, whatever the weather, set your preferred temperature for the best working conditions. Fully automatic climate control system adjusts air temperature and fan speed to maintain your ideal climate setting.

### Adjustable steering column

Enhance your driving comfort, and work without fatigue, by easily adjusting the steering column's tilt and telescopic movements to fit your preferred position.

### Colour LCD monitor panel

The 5.7" LCD panel is suitable for day and night work. The user-friendly monitor has two customisable screen displays (per operator's preference), giving full access to machine settings and maintenance data. Any abnormality is clearly displayed on the screen, allowing you to work safely and confidently with an accurate overview of all conditions.





1. Radio
2. Climate control HVAC
3. Storage compartment for sunglasses & sun visor
4. Colour rear-view camera
5. Opening emergency exit
6. Joystick or fingertip control
7. Large control armrest
8. Improved visibility on the bottom left & right
9. Colour LCD monitor panel

10. Multi-settings high-comfort air-suspension seat
11. Large storage compartments
12. Emergency engine stop switch
13. Large ergonomic pedals
14. Flat, spacious, easy-to-clean floor
15. Fuse box
16. Extinguisher location

# Expert control with maximum safety

## ▣ Safe operation in all simplicity

Power alone is not enough – for maximum efficiency, it needs to be matched by precise control. Our unique range of features allows every operator to get the most out of these impressive machines.

Safety is crucial to your company and your employees – so, these machines feature large platforms, hand-rails, and 2 emergency exits, with maintenance performed from the ground.

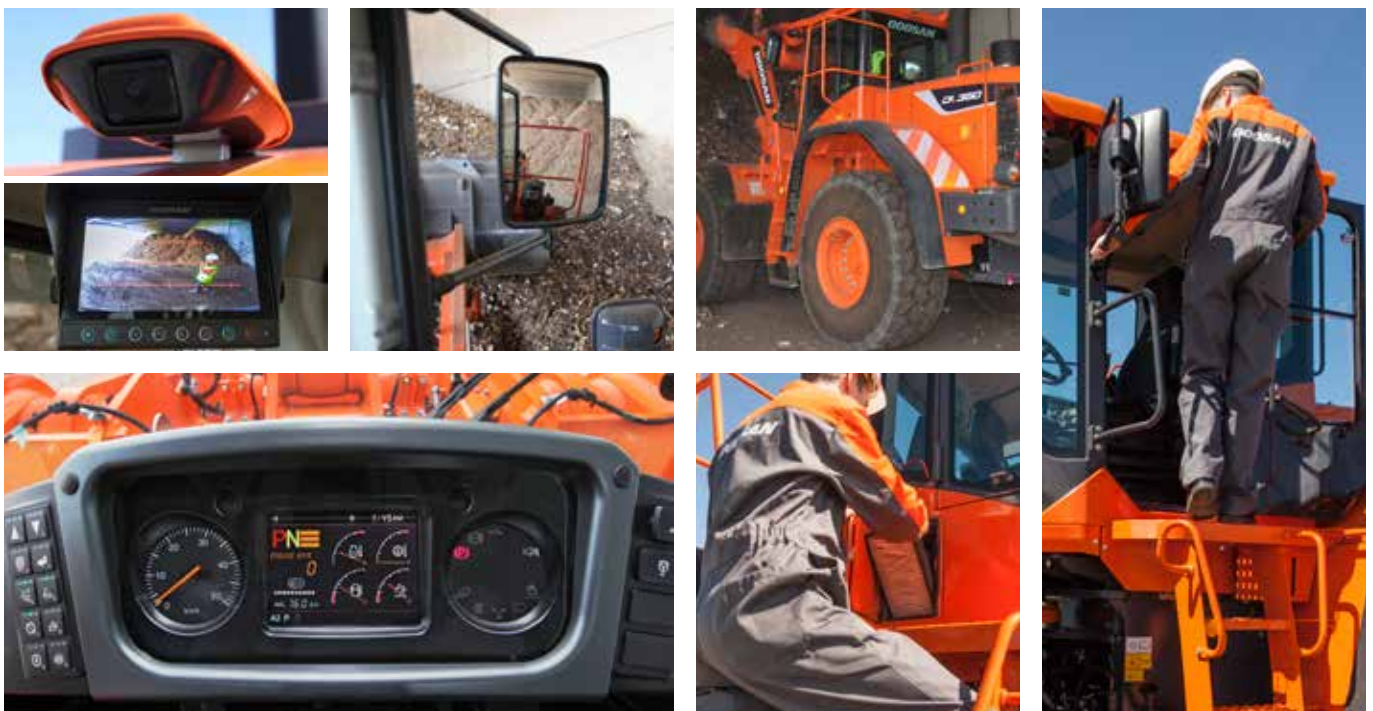

### Rear view camera

A camera provides a clear view of what's happening behind the machine for added safety and peace of mind. The full colour display screen in the cabin shows the operator what the camera sees. The panoramic view shows trucks coming up behind the loader or people on the ground, and some indicators provide a good perception of distances.

### External mirrors

The external mirrors are heated to ensure visibility and prevent accidents in cold weather.

### Full fenders

To keep them clean and avoid mud splashing on the windows or accidents on slippery steps, Doosan's wheel loaders are standard equipped with full fenders and mud guards.

### Cab

To ensure a healthy work environment, the cab air is filtered twice to eliminate all particles larger than 2 microns. Plus, the cab satisfies ROPS/FOPS regulations – a wide emergency exit (located on the right side) provides fast, easy evacuation in a critical situation.

### Safe maintenance

All the daily gauges checking takes place from the ground, to be operate quickly and safely by everyone.

Doosan has also installed an automatic greasing system (as standard) to reduce working time and increase operating comfort.

### Safe access

To facilitate access and mobility on the machine, multiple hand-rails ensure that the operator always has a firm support to hold on to.

### Driving assistance

- Automatic transmission with smooth shift transition
- Automatic transmission kick-down
- Automatic Hydraulic Differential Lock (HDL)
- Automatic Lift-arm Suspension (LIS)
- Automatic kick-out function on lift arm
- Automatic return to dig position
- Automatic reversing fan
- Automatic greasing system
- Automatic lock-up on torque converter



Joystick steering



Fingertip

**Ergonomic controls:** All controls are placed within the operator's easy reach. Clearly positioned for comfortable access, and grouped by function, they enable safe, confident operation. The bucket is controlled by using a convenient joystick or with fingertip levers. Both include an FNR reversing switch and kick-down function.

# Reliability, the habit of a lifetime

## ▣ Dependable performance for low lifetime cost

Doosan has been building heavy construction equipment for 40 years. This extensive experience is reflected in the superior design and development of our wheel loaders and by an extensive logistics network. Plus, our standard machines include a wide range of features at no extra cost (other manufacturers offer these only as options).



### Designed to last

We pay the closest attention to the design and manufacture of structural components. Finite Element Analysis is used to ensure an extended lifetime for main structures such as the chassis, joints and lift arm. Then, after modelling, they are subjected to intensive laboratory and field testing in extreme conditions. Ongoing statistical analysis is used to continually increase reliability.

### Durable steel parts

Rear parts – such as the radiator grille, engine bonnet and fenders – are made of solid steel. They're also designed for easy repair, reducing the need to replace them if they are damaged.

### Articulation hinges

The robust hinges feature a clean and solid design – and the 40° articulation angle and steering radius are the best in their class.

### Exhaust

The inner exhaust pipe sucks air out of the engine compartment through an outer pipe – this "chimney" effect provides constant air circulation and prevents deposits of flammable material on hot parts.

### Auto-lube

The DL300-5 & DL350-5 are standard equipped with an automatic central greasing system: 'Auto-lube' protects components for longer machine lifetime.

### ORFS (O-Ring Face Seal)

All hydraulic lines, even the low pressure circuits, are sealed with ORFS couplings to prevent leaks.



**Limited slip differentials:** Limited slip differentials at the front and rear automatically ensure maximum traction and easy driving over soft and muddy ground with no need for a manual differential lock. They also reduce the risk of skidding and prevent excessive tyre wear. An optional hydraulic differential-lock can be activated automatically if one tyre starts to slip. The outboard disc brakes enable easy service without dismantling the axles.

# Simple maintenance with maximum uptime

## ▣ Excellent service accessibility

Short maintenance operations at long intervals mean you can depend on your equipment being available on-site when it's needed. Our machines are designed for simple routine maintenance, while skilled Doosan technicians are available to provide extra support when you need it. To get the most out of your machine, you can choose the package you need from a broad range of service agreements. Uptime, productivity and residual value are all maximised, making these wheel loaders an economical and rewarding choice.

Building further on the success of the Stage IIIB engines, the new Stage IV Scania engine has no need for a DPF filter to meet the Stage IV emissions requirements. Which means no maintenance required – resulting in more uptime!



### Maintenance access made simple

- The front and rear of the radiator – which is made of aluminium for the highest pressure resistance and a long lifetime – are easily accessible
- Air enters through the side and top. Swing doors provide easy access for maintenance
- A battery cut-off switch makes it easy to disconnect the battery during long-term storage
- The hour meter display can be easily checked without turning the engine on

### Triple-element air filter

The forced-air cleaner removes 99% of particles and is backed up by a turbo pre-filter. Cleaning and cartridge replacement are only needed at long intervals.

### Engine

The Scania EMS (Engine Management System) uses a CAN (Controller Area Network) to provide a constant flow of operating information as well as diagnostic and ECU programming functions.

### SCR Tank

Connected to the ECU, sensors in the tank detect low levels of AdBlue® and any system malfunction.

### Global Doosan network

With a network of Doosan dealers & Parts Distribution Centres worldwide, your Doosan wheel loader can be serviced & maintained wherever you are. Our service centre in the heart of Europe has more than 40,000 parts in stock to supply you with top-quality components as quickly as possible.

### Full solution provider

- The Doosan Telematic system is available as standard – offering you all of the features for reading out vehicle operating & production parameters remotely, and providing you with total ease-of-mind
- Protection+: an extended warranty covering parts, travel and service (check with your local dealer)
- Maintenance contract: your dealer will support you with routine service at regular intervals
- Genuine parts: manufactured and tested to ensure they always meet the same high quality standards as the original components

### Reversing 90° swing fan

The fan is located behind the radiator, and air is sucked in from the sides, not from behind the machine. Easier cleaning access to one-block radiator from the rear and the front. The operator can easily set standard intervals for fan reverse from the LCD display. Performance is regulated for lower fuel consumption and shorter warm-up periods.



Battery cut-off switch



Centrifugal pre-cleaner  
Turbo III



Drains



Wheel chocks

# Technical specifications

## Engine

Scania Stage IV (Tier 4 final) compliant diesel engine fully meets the latest emissions regulations.

XPI direct injection (Extra high Pressure Injection) ensures very good fuel efficiency. Variable geometry turbocharger delivers high power and strong torque, even at low idle.

Electronic engine controls optimise machine performance and manage the catalytic operations by a Diesel Oxidation Catalyst (DOC) and a Selective Catalytic Reduction (SCR)

	DL300-5	DL350-5
Model	Scania DC9	
Regulation compliant	Stage IV	
No. of cylinders	5	
Nominal power - Gross (SAE J1995)	271 hp (202 kW) at 1800 rpm	
Maximum torque - Gross	1275 Nm at 1400 rpm	
Idle (low - high)	900 - 2130 [±20] rpm	
Displacement	9.3 litres	
Bore × stroke	130 mm × 140 mm	
Starter	24 V - 6 kW	
Batteries - Alternator	2 × 12 V, 200 Ah - 28 V, 100 Ah	
Air filter	Centrifugal pre-cleaner Turbo III with 2-stage Donaldson dry filter.	
Cooling	Cooling package with automatic reversing fan to facilitate radiator cleaning. Automatic rotation speed adjustment according to temperature conditions.	

## Transmission

5-Gear powershift transmission with 3 operating modes: manual, fully automatic or semi-automatic with "kick-down" function.

Based on high-quality components. Equipped with a modulation system for protection and smooth gear and direction changes. A manual transmission control lever is located to the left of the steering wheel. Direction change function also available in automatic or semi-automatic mode. Transmission can be disengaged by the brake pedal to deliver full engine power to the hydraulics system. A safety device prevents the engine from starting if the transmission is not in neutral. Torque converter lock-up function from 2nd to 5th gear. Transmission testing and adjustment equipment available.

	DL300-5	DL350-5
Type	ZF 5 WG 230 + lock-up	
Torque converter	Simple stage / mono phase / fixed wheel stator	
Speeds - Forward 1-2-3-4-5	6.0 - 11.0 - 17.0 - 26.0 - 37.0 km/h	
Speeds - Reverse 1-2-3	6.5 - 11.5 - 27.5 km/h	
Maximum traction	18.4 t	18.3 t
Maximum gradeability	51% / 27°	

## Axles

Front & rear axles manufactured by ZF with outboard planetary reduction gears. The front and the rear are equipped with Limited Slip Differential (LSD), which means the machine has the optimum traction in all conditions. 18.4 t traction power allows operation on slopes of 51%.

	DL300-5	DL350-5
LSD lock ratio	30% (Front & Rear)	
HDL lock ratio	100%	
Oscillation angle	+/- 12°	

## Hydraulic system

	DL300-5	DL350-5
Type	Load sensing - closed centre hydraulic system	
Main pump	Dual variable displacement axial pistons pumps	
Maximum flow	290 l/min	
Maximum pressure	250 bar	
Pilot system	Automatic functions for positioning the bucket ready to dig and a function for stopping the lift arm at the desired height, and low position adjusted manually by switch, are standard.	
Filtration	In the oil return to the tank, the fibre glass filter has a filtering capability of 10 micron.	

## Lift arm

Z-kinematics with simple lifting piston system designed for heavy-duty applications. 17.2 ton breakout force combines with a bucket angle that is maintained throughout the range of movement. Bucket angles are optimised in the travelling position and at ground level. Load Isolation System (LIS) is fitted as standard for improved operator comfort, output and lifetime.

### Load cycle

	DL300-5	DL350-5
Lift arm - up	5.8 s	
Lift arm - down	3.2 s	
Bucket - crowd	2.2 s	
Bucket - dump	1.4 s	

### Hydraulic cylinders

	Quantity	DL300-5 Bore × rod diameter × stroke (mm)	DL350-5 Bore × rod diameter × stroke (mm)
Lift	2	140 × 80 × 831	150 × 95 × 800
Bucket	1	180 × 105 × 515	180 × 105 × 535

## Brakes

Dual multi-disc circuit with sintered metal discs for extended service life. Braking system activated by a pump and accumulator circuits. Spring-applied, hydraulically released parking brake is mounted on the transmission shaft and accumulator circuits and is electronically activated.

Brake type: spring-applied / hydraulically released.

Brake pump with variable displacement axial pistons provide 60 l/min.

Operator can activate/deactivate the Clutch Cut Off on the brake pedal from a switch and can adjust the sensor proximity with the same switch.

The emergency brakes are composed of a double system continually under pressure by accumulators.

	DL300-5	DL350-5
Braking distance	10.5 m at 33 km/h	12.0 m at 32 km/h
Number of disc brakes per wheel (front / rear)	5 / 5	
Accumulators	0.75 l - 30 bar	



## ➤ Cab

Safety compliance with Roll Over Protection System (ROPS) and Falling Object Protective Structure (FOPS) requirements.

Spacious modular cab with excellent all-round visibility and ample storage space. Good overview of the bucket, tyres and loading area thanks to wide windows. Push-button controlled air conditioning and heating with air recirculation function. Double cab air filter installed in the cab with extra protection for the operator in dusty or polluted environments. Viscous suspension mount for maximum comfort. Adjustable high-quality heated seat with air suspension, arm rests and height and tilt adjustable steering column. All operating information clearly displayed in front of the operator. Control functions are centralised on a console on the right.

	DL300-5	DL350-5
Safety standards	ROPS ISO 3471:2008 FOPS ISO 3449	
Door	1	
Emergency exits	2	

## ➤ Noise emissions

	DL300-5	DL350-5
A weighted emission sound pressure level at the operator position (ISO 6396)	Declared: 73 dB(A) Measured: 71.9 dB(A)	Declared: 71 dB(A) Measured: 70 dB(A)
A weighted emission sound power level at external position (ISO 6395)	Declared: 107 dB(A) Measured: 105.4 dB(A)	Declared: 106 dB(A) Measured: 105 dB(A)

## ➤ Fluid capacities

	DL300-5	DL350-5
Fuel tank	241 l	
Urea (AdBlue®) tank	38 l	
Cooling system	50 l	
Engine oil	34 l	
Front axle	42 l	
Rear axle	42 l	
Hydraulic system	180 l	
Transmission oil	54 l	

## ➤ Steering system

	DL300-5	DL350-5
Type	Load sensing with amplification stage and priority valve	
Steering angle	40°	
Oil flow	145 l/min	
Operating pressure	200 bar	
Steering cylinders (2)	Emergency steering system with electric motor-driven hydraulic pump.	
Bore × rod diameter × stroke	80 × 40 × 443	100 × 50 × 450

## ➤ Pressure settings

	DL300-5	DL350-5
Working (pump cut-off)	250 ± 10 bar	
Steering relief – LS port side	185 ± 5 bar	
Steering relief – steering pump side	200 ± 5 bar	
Pilot control	28 ± 2 bar	
Brake accumulator charging	120~140 bar	
Service brake	60 ± 3 bar	
Fan motor	130 ± 10 bar	145 ± 10 bar
Parking brake release	120 ± 5 bar	
Transmission selection pressure	17 ± 1 bar	



# Technical specifications

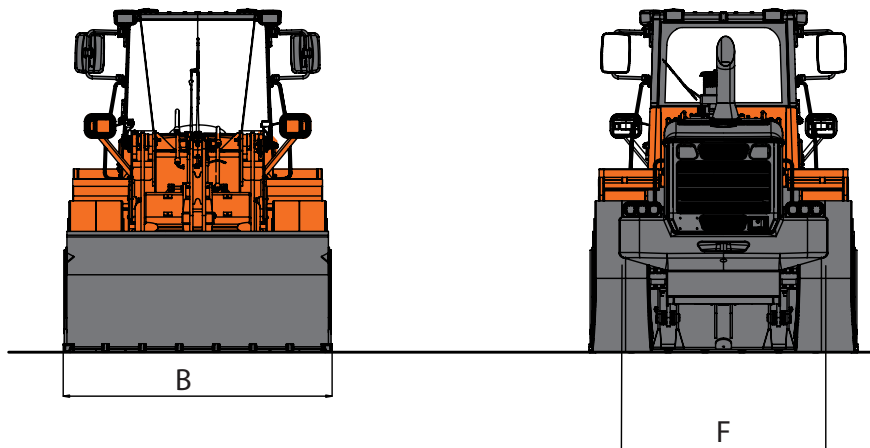
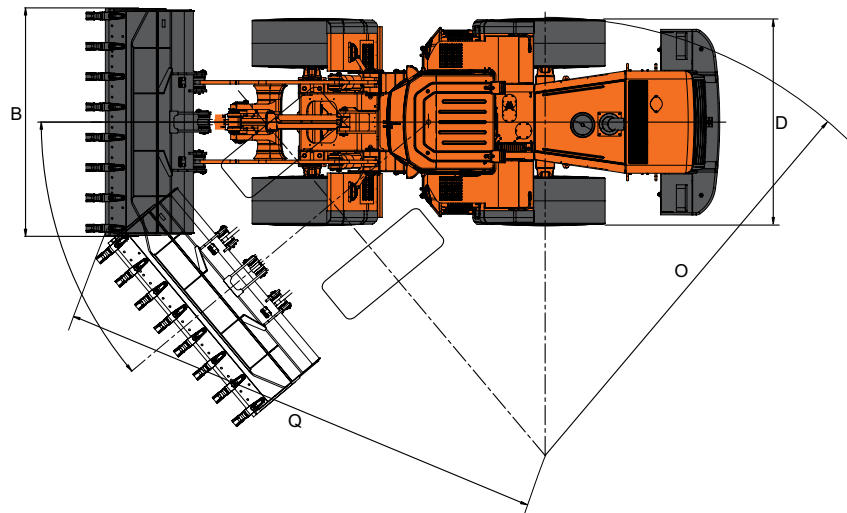
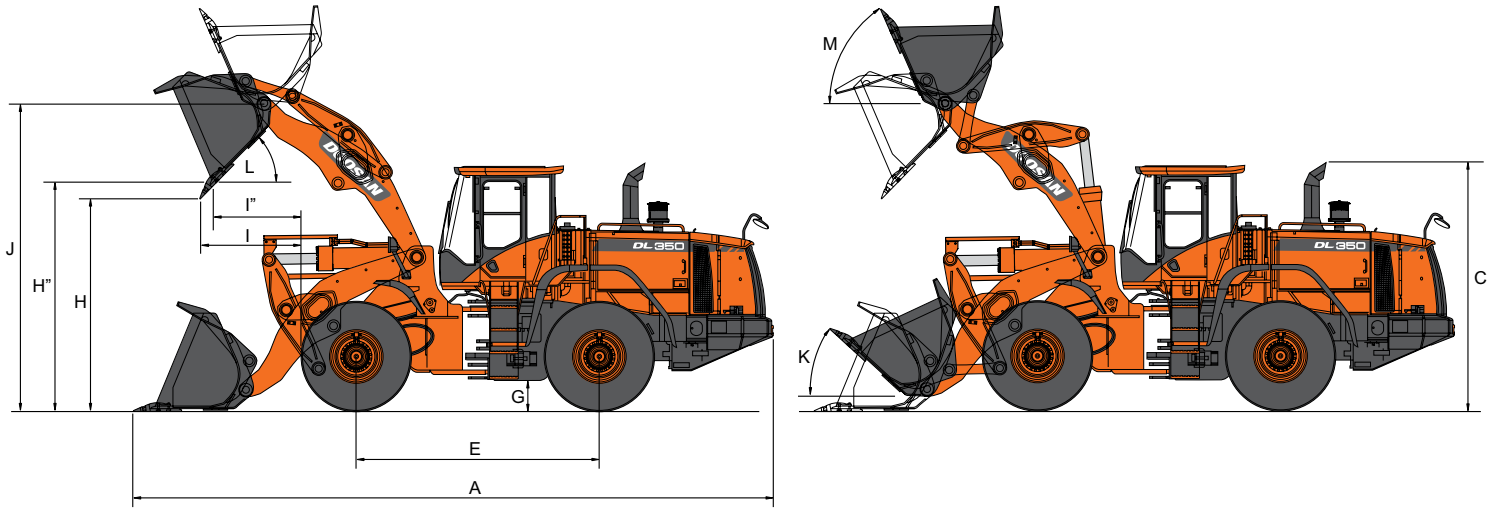

## ➤ Dimensions and operational data

DL300-5 – Pin-on	Configuration	General purpose						High Lift	
		Teeth	Bolt-on edge	Teeth	Bolt-on edge	Teeth (Mono)	Teeth & segments	Bolt-on edge	
	Capacity heaped ISO/SAE	m <sup>3</sup>	3.0	3.2	2.7	2.9	3.0	3.2	3.2
B	Bucket width	mm	2920	2920	2920	2920	2920	2920	2920
	Breakout force	kN	169	168	178	177	167	169	163
	Static tipping load (straight)	kg	15530	15380	15430	15280	15530	15310	12210
	Static tipping load (at full turn)	kg	13720	13580	13620	13490	13710	13520	10780
H	Dump height (at 45° – fully raised)*	mm	2725	2845	2760	2880	2750	2725	3395
I	Dump reach (at 45° – fully raised)*	mm	1290	1160	1250	1120	1300	1260	1185
	Dump height (at max. dump) – (at max. reach)*	mm	640	800	685	850	670	640	840
	Dump reach (at max. dump) – (at max. reach)*	mm	1435	1360	1415	1345	1415	1435	1955
	Digging depth	mm	125	125	125	125	120	125	250
J	Height at bucket pivot point	mm	3975	3975	3975	3975	3975	3975	4530
	Max. tilt angle in carry position	°	49	49	49	49	49	49	51
M	Max. tilt angle fully raised	°	61	61	61	61	61	61	57
K	Max. tilt angle on ground	°	45	45	45	45	45	45	45
	Max. tilt angle at max. reach	°	61	61	61	61	61	61	59
	Max. dump angle at max. reach	°	69	69	69	69	69	69	61
	Max. dump angle on ground	°	71	71	71	71	71	71	66
L	Max. dump angle fully raised	°	45	45	45	45	45	45	45
O	External radius at tyre side	mm	5800	5800	5800	5800	5800	5800	5800
Q	External radius at bucket edge	mm	6455	6405	6440	6395	6445	6450	6650
E	Wheel base	mm	3200	3200	3200	3200	3200	3200	3200
D	Width at tyres	mm	2760	2760	2760	2760	2760	2760	2760
F	Tread	mm	2150	2150	2150	2150	2150	2150	2150
G	Ground clearance (at 12° osc.)	mm	435	435	435	435	435	435	435
A	Overall length	mm	8270	8095	8220	8045	8235	8270	8605
C	Overall height	mm	3475	3475	3475	3475	3475	3475	3475
	Operating weight	kg	18865	18890	18805	18920	18840	19020	19445

DL350-5 – Pin-on	Configuration	General purpose					Light material		High Lift	
		Teeth	Bolt-on edge	Teeth	Bolt-on edge	Teeth (Mono)	Teeth	Bolt-on edge	Bolt-on edge	
	Capacity heaped ISO/SAE	m <sup>3</sup>	3.3	3.5	3.5	3.7	3.7	3.7	3.9	3.7
B	Bucket width	mm	3000	3000	3000	3000	3000	3110	3110	3000
	Breakout force	kN	165	164	165	164	164	165	164	160
	Static tipping load (straight)	kg	15980	15720	16130	15810	15730	16080	15730	12460
	Static tipping load (at full turn)	kg	14110	13880	14240	13960	13890	14200	13890	11000
H	Dump height (at 45° – fully raised)*	mm	2920	3040	2920	3040	2920	2920	3040	3565
I	Dump reach (at 45° – fully raised)*	mm	1350	1220	1350	1220	1350	1350	1220	1425
	Dump height (at max. dump) – (at max. reach)*	mm	640	805	640	805	640	640	805	825
	Dump reach (at max. dump) – (at max. reach)*	mm	1550	1485	1550	1485	1550	1550	1485	2115
	Digging depth	mm	90	90	90	90	90	90	90	235
J	Height at bucket pivot point	mm	4170	4170	4170	4170	4170	4170	4170	4695
	Max. tilt angle in carry position	°	48	48	48	48	48	48	48	51
M	Max. tilt angle fully raised	°	64	64	64	64	64	64	64	63
K	Max. tilt angle on ground	°	45	45	45	45	45	45	45	45
	Max. tilt angle at max. reach	°	65	65	65	65	65	65	65	63
	Max. dump angle at max. reach	°	71	71	71	71	71	71	71	66
	Max. dump angle on ground	°	74	74	74	74	74	74	74	74
L	Max. dump angle fully raised	°	45	45	45	45	45	45	45	45
O	External radius at tyre side	mm	6050	6050	6050	6050	6050	6050	6050	6050
Q	External radius at bucket edge	mm	6605	6615	6605	6615	6605	6655	6665	6915
E	Wheel base	mm	3300	3300	3300	3300	3300	3300	3300	3300
D	Width at tyres	mm	2750	2750	2750	2750	2750	2750	2750	2750
F	Tread	mm	2150	2150	2150	2150	2150	2150	2150	2150
G	Ground clearance (at 12° osc.)	mm	430	430	430	430	430	430	430	430
A	Overall length	mm	8495	8320	8495	8320	8495	8495	8320	8960
C	Overall height	mm	3475	3475	3475	3475	3475	3475	3475	3475
	Operating weight	kg	19625	19745	19625	19750	19805	19660	19795	20295

(\*): measured to the tip of the bucket teeth or bolt-on edge. Tyre size 23.5 R25 (L3)

# Attachments

## ▣ A Doosan attachment for optimum performance in each activity

Robust construction, excellent penetration, covering several types of applications from light- up to severe-duty. These new Doosan loader attachments are designed and manufactured in Europe to meet local requirements and standards. A large range of attachments guarantees versatility and efficiency all the way. Each bucket is designed for a specific machine model to fit its key kinematic parameters perfectly. Critical bucket positions are optimised to improve digging and dumping. The Doosan attachment concept stands for high quality, perfect fit and excellent operational capabilities.



### General purpose buckets

General purpose buckets provide good all-round performance for stockpiling and material-handling operations. With its sloped bottom design for optimum bucket filling capabilities and load retention, this is the perfect bucket for day-to-day material handling. It can be equipped with optional teeth, shrouds and cutting edge, depending on the customer's requirements.



### Heavy-duty buckets

Heavy-duty bucket suitable for a range of applications that require a robust construction (such as sand handling or occasional severe loading). Parts subjected to high stress – such as the edge, sidebars and corner protections – are made of hardened steel. Optional teeth, shrouds and reversible cutting edge allow you to tailor the bucket to the customer's needs.



### V-shape Rock buckets

Used for handling and digging of hard compacted material and blasted rock in mining or quarry applications, where high break-out force is required. Severe digging is no problem for this tough bucket, made entirely of highly wear-resistant steel with a hardness of 420 BHN. Weld-on ESCO® teeth come standard.



### Light material buckets

When you need to move large amounts of light material, this bucket is the most profitable and rewarding choice. Its convex sides allow high capacity and avoid material spilling. Comes standard with a bolted reversible cutting edge.



### High dump bucket

The high dump bucket is suitable for light material handling applications. This bucket improves the unload height and increases the versatility of the wheel loader. Its convex sides allow high capacity and avoid material spilling. Comes standard with a bolted reversible cutting edge.



### Grapple bucket

The grapple bucket is designed to provide good all-round performance for material-handling applications. Depending on the application, the side can be convex for good capacity, or carved to improve the material grip. Different types of grapple available; comes standard with a bolted reversible cutting edge.



### Pallet forks

For loading and unloading different types of pallets as well as normal forklift operations.



### Quick-coupler

Particularly interesting when the machine has a wide variety of jobs to carry out, this hydraulic quick-coupler enables a variety of attachments to be changed quickly and safely.

### Bucket selection chart DL300-5

Lift arm	Bucket	Type	m <sup>3</sup>	Material Density [t/m <sup>3</sup> ]																	
				1.0	1.1	1.2	1.3	1.4	1.5	1.6	1.7	1.8	1.9	2.0	2.1	2.2	2.3	2.4			
Standard lift arm	General purpose	Adapter Tooth (122 mm)	3.0									3.5 m <sup>3</sup>						2.9 m <sup>3</sup>			
		Cutting edge tooth (122 mm)	3.2								3.7 m <sup>3</sup>				4.6 m <sup>3</sup>						
		Adapter Tooth	2.7												3.1 m <sup>3</sup>					2.6 m <sup>3</sup>	
		Cutting edge tooth	2.9										3.3 m <sup>3</sup>							2.8 m <sup>3</sup>	
		Mono tooth	3.0										3.5 m <sup>3</sup>							2.9 m <sup>3</sup>	
		Tooth & segment edge	3.2								3.7 m <sup>3</sup>									3.0 m <sup>3</sup>	
High lift arm	General purpose	Adapter Tooth	3.0						3.5 m <sup>3</sup>										2.9 m <sup>3</sup>		
		Cutting edge tooth	3.2					3.7 m <sup>3</sup>											3.0 m <sup>3</sup>		
		Adapter Tooth	2.7									3.1 m <sup>3</sup>								2.6 m <sup>3</sup>	
		Cutting edge tooth	2.9								3.3 m <sup>3</sup>									2.8 m <sup>3</sup>	
		Mono tooth	3.0							3.5 m <sup>3</sup>										2.9 m <sup>3</sup>	
		Tooth & segment edge	3.2						3.7 m <sup>3</sup>											3.0 m <sup>3</sup>	

### Bucket selection chart DL350-5

Lift arm	Bucket	Type	m <sup>3</sup>	Material Density [t/m <sup>3</sup> ]																	
				1.0	1.1	1.2	1.3	1.4	1.5	1.6	1.7	1.8	1.9	2.0	2.1	2.2	2.3	2.4			
Standard lift arm	General purpose	Adapter Tooth	3.3									3.8 m <sup>3</sup>							3.1 m <sup>3</sup>		
		Cutting edge tooth	3.5								4.0 m <sup>3</sup>									3.3 m <sup>3</sup>	
		Adapter Tooth	3.5									4.0 m <sup>3</sup>								3.3 m <sup>3</sup>	
		Cutting edge tooth	3.7									4.3 m <sup>3</sup>								3.5 m <sup>3</sup>	
		Tooth & segment edge	3.7									4.3 m <sup>3</sup>								3.5 m <sup>3</sup>	
		Adapter Tooth	3.7									4.3 m <sup>3</sup>								3.5 m <sup>3</sup>	
		Cutting edge tooth	3.9								4.5 m <sup>3</sup>									3.7 m <sup>3</sup>	
High lift arm	General purpose	Adapter Tooth	3.3																3.1 m <sup>3</sup>		
		Cutting edge tooth	3.5																	3.3 m <sup>3</sup>	
		Adapter Tooth	3.5																	3.3 m <sup>3</sup>	
		Cutting edge tooth	3.7																	3.5 m <sup>3</sup>	
		Tooth & segment edge	3.7																	3.5 m <sup>3</sup>	
		Adapter Tooth	3.7																	3.5 m <sup>3</sup>	
		Cutting edge tooth	3.9																	3.7 m <sup>3</sup>	

Compliant with ISO 14397-1 (2007). The filling factor depends on the type of material, the working conditions and the experience of the operator.

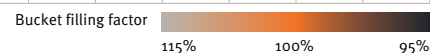

### Density of operating materials

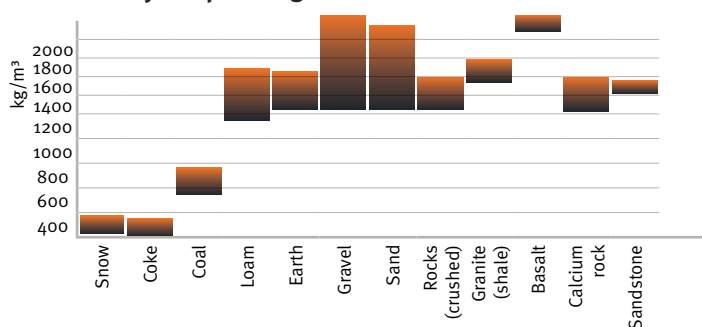

The specific weight of the material largely depends on the level of humidity, the degree of compaction, composition, etc.

# Standard and optional equipment

## Performances

	DL300-5	DL350-5
Scania, Stage IV compliant, SCR, EGR, DOC, water-cooled, diesel engine with Variable Turbo Charger and air-to-air intercooler	●	●
No DPF	●	●
Engine power mode selector switch (Standard / Economy & Power mode)	●	●
Power-up pedal function by full stroke of acceleration	●	●
Auto shut-off engine	●	●
Fuel heater	○	○
Torque converter lock-up	●	●
Transmission clutch cut-off via the brake pedal	●	●
Transmission mode selector switch (Manual / Auto 1 ↔ 5 / Auto 2 ↔ 5 with kick-down)	●	●
Automatic hydraulic load sensing system, variable displacement pump	●	●
Limited slip differentials on front and rear axles	●	●
Hydraulic lock differentials on front axle	○	○
Counterweight	●	●
Robust Z bar lifting system	●	●
High lift loader	○	○
Quick coupler	○	○
Wide range of buckets	○	○

## Comfort

Load isolation system (LIS)	●	●
Automatic lift arm kick-out	●	●
Automatic return to dig	●	●
Levelling function	●	●
3rd hydraulic function	●	●
Automatic air conditioning with electronic climate control	●	●
Grammer air-suspension seat with safety belt 2 points	●	●
Electric joystick steering on armrest	○	○
Mono control lever with FNR switch	●	●
Fingertip levers	○	○
Adjustable steering column (tiltable & telescopic)	●	●
Tinted safety glass	●	●
Left sliding window	●	●
Right opening window (180°)	●	●
Floor mat	●	●
Multiple storage compartments	●	●
Cup holder	●	●
Loudspeakers and connections for radio	●	●
Shark antenna for radio	●	●
Lift arm float kick-out	●	●
Alternator 28 V / 100 Ah	●	●
Dashboard monitoring with LCD display (dials, gauges and lamps)	●	●
Interior cab light	●	●
Cigarette lighter and 12 & 24 Volt power sockets	●	●
Weighing system	○	○

## Safety

Emergency steering pump driven by electric motor	●	●
Full fenders with rubber protection	●	●
ROPS cab (SAE J 394, SAE 1040, ISO 3471)	●	●
FOPS cab (SAE J 231, ISO 3449)	●	●
Double filtered air cab	●	●
Right opening window (emergency exit)	●	●
Front and rear wiper and washer	●	●
Retractable roller sun visor	●	●
Road lights: low and high beam, tail indicators, stop, reversing lights	●	●
Work lights: 2 halogen at the front and 4 at the rear (6 × 70 W)	●	●
Work lights: 2 xenon at the front and 4 halogen at the rear (6 × 70 W)	○	○
Reverse travel alarm	●	●
Rotating beacon	●	●
Horn	●	●
Heated external mirrors	●	●
Interior rear view mirrors	●	●
Anti-slip steps & platforms	●	●
Starting safety system	●	●
Engine exhaust brake	●	●
Brake circuits with accumulator	●	●
Dual service brake pedals	●	●
Electric parking brake on the transmission, spring-applied hydraulic release	●	●
Wheel chocks	●	●

## Other

Bottom protection plates	●	●
Tie hooks	●	●
Articulation lock in the transport position	●	●
Towing hitch	●	●
Tyres 23.5 R25 (L3)	●	●
Tyres 23.5 R25 (L2)	○	○
Tyres 23.5 R25 (L5)	○	○

## Maintenance

	DL300-5	DL350-5
Automatic lubrication system	●	●
Hydraulic reversing engine fan	●	●
"CORE TMS" Telematic system	●	●
Self-diagnosis system & monitoring indicator by the dashboard, plus electronic plug for fast adjustment	●	●
Fast couplers for hydraulic check	●	●
External drains for engine oil and coolant changes	●	●
Bio oil	○	○
3-year warranty	○	○
Protection+ warranty	○	○

Standard: ●  
Optional: ○



Electric steering



Fingertip control



High lift arm



Differential hydraulic lock



Heavy-duty tyre



Protection+ warranty



Quick coupler



Attachments

Some of these options may be standard in some markets. Some of these options may not be available for certain markets. Please check with your local DOOSAN dealer for more information about availability or to adapt your machine to your application needs.



**"CORE TMS" Doosan Telematic system:** is the technology of sending, receiving and storing information via telecommunication devices in conjunction with affecting control on remote objects. In a dual mode (satellite, GSM), it provides many details about the performance of your equipment – such as operation hours, fuel efficiency, GPS, fault code/warning and reports.

# SIMPLICITY WORKS

WHEN IT COMES TO DOOSAN...

